



ENERGIZE YOUR LIFESTYLE

Gener (EEC L1e-B)



COC



Color

Jiangsu Lvneng Electrical Bicycle Technology Co.,Ltd
No 158 Shengjia Village,Wuyivillage,Hengshangqiao Town,Wujin District, Changzhou,Jiangsu

Tel: 0086-519-68217082

www.lvmoto.com





Specifications

MODEL

Gener (EEC L1e-B)

DIMENSION (L*W*H)	1620*755*1050 MM
PACKING SIZE	1690 *420*1170 MM
WHEELBASE	1160 MM
MOTOR	810W BOSCH MOTOR
BATTERY	48V24AH LITHIUM BATTERY
TYRE SIZE DESIGNATION FRONT	2.75-10; 250KPA ; 2.15-10
TYRE SIZE DESIGNATION REAR	2.75-10 ; 250KPA; 2.15-10
BRAKE	FRONT DISC BRAKE.REAR DRUM BRAKE
MAX.SPEED	25 KM/H
MAX.RANGE	80-100 KM
SLOPE HILL-ABILITY	9° (13%)
TECHNICALLY PERMISSIBLE MAXIMUM LADEN MASS	168KG
NUMBER OF SEATING POSITIONS	1
REMOVE CONTROL ALARM	● YES
USB	● YES
BLUETOOTH	● NO
CONTAINER LOADING	20'GP/32PCS 40'GP/70PCS

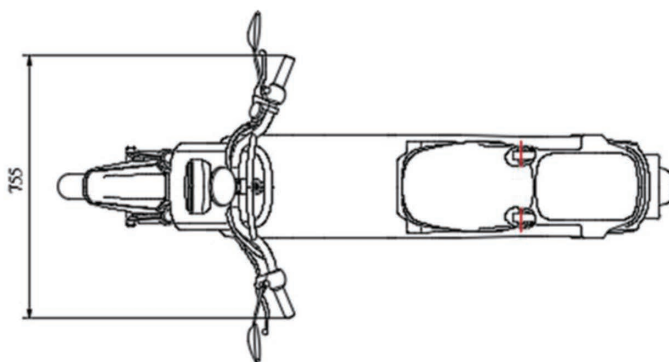
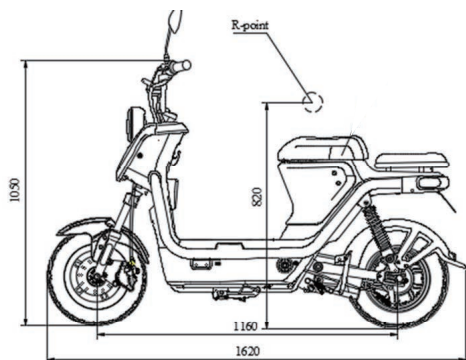

Units: mm