



ENERGIZE YOUR LIFESTYLE

**LX02 (EEC L1e-B)**



**COC**



Color

Jiangsu Lvneng Electrical Bicycle Technology Co.,Ltd  
No 158 Shengjia Village,Wuyivillage,Hengshangqiao Town,Wujin District, Changzhou,Jiangsu

Tel: 0086-519-68217082

[www.lvnmoto.com](http://www.lvnmoto.com)





## Specifications

### MODEL

**LX02 (EEC L1e-B)**

DIMENSION (L\*W\*H)

1740\*680\*1090MM

WHEELBASE

1240MM

MOTOR

2.05KW **BOSCH** MOTOR

BATTERY

2\*60V26AH (1,560WH) LITHIUM BATTERY (PORTABLE)

TYRE SIZE

3.0-10" TUBELESS

BRAKE

FRONT &amp; REAR DISC BRAKE

MAX.SPEED

45 KM/H

MAX.RANGE

75 - 150 KM

MAX.LOADING

150 KG

SLOPE HILL-ABILITY

13° (25%)

PACKING SIZE

1750 X 575 X 1205 MM

CONTAINER LOADING

10 PCS/20'GP; 52 PCS/40'HQ

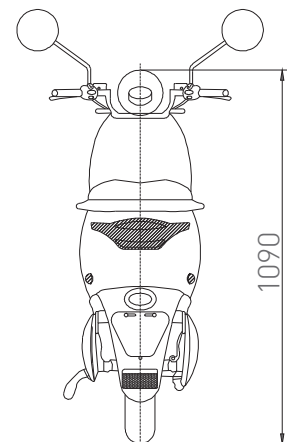
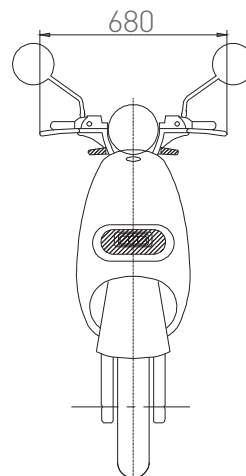
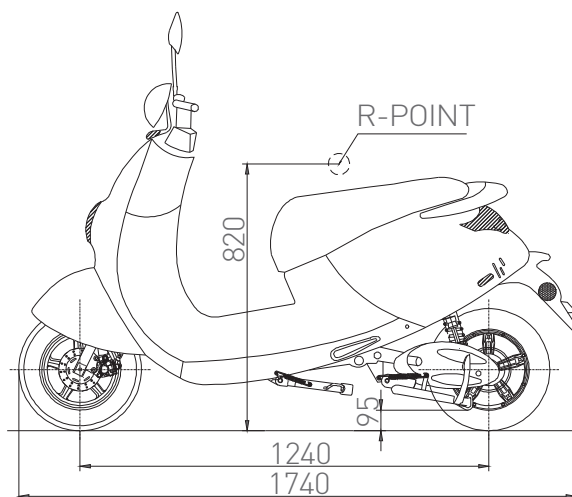

Units: mm